

NEW PRODUCTS

Contact No.110

Issued May 16, 2005

LEAD-FREE AND ENVIRONMENTALLY FRIENDLY

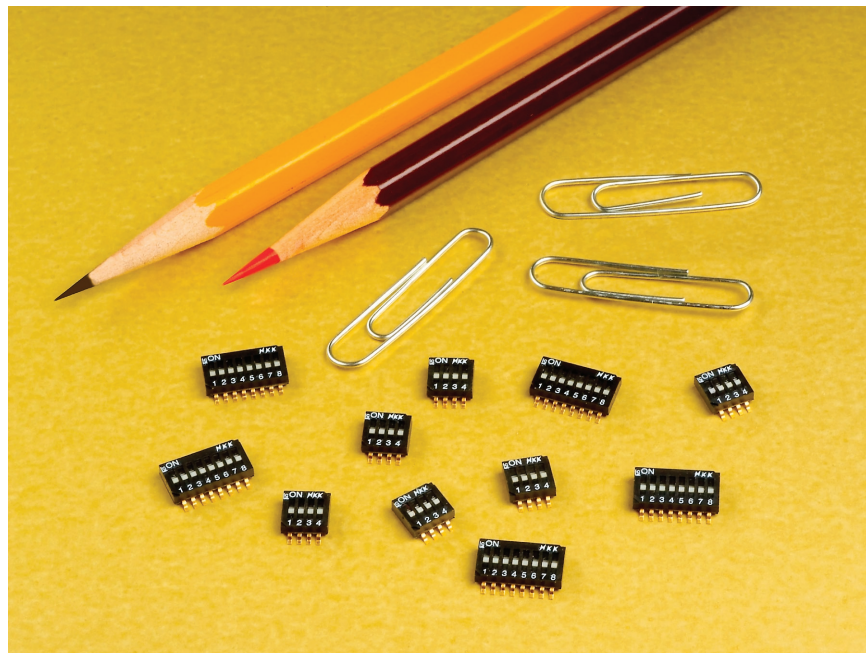

SERIES JS04

DIP Slide Switch

Available:
May 16, 2005



715-1, Unane, Takatsu-ku, Kawasaki-shi,
213-8553 Japan
phone: +81-44-813-8008
fax: +81-44-813-8038
www.nikkaiswitches.com
E-mail: overseas@nikkai.co.jp



Distinctive Characteristics

Suited to lead-free solder processing applications because of heat resistant resin materials.

Components and packaging materials meet RoHS directive restricting use of hazardous substances such as lead, cadmium, mercury, hex chrome, PBB, and PBDE.

Heat resistant resin used for case allows vapor phase and infrared convection reflow soldering.

Sliding contacts provide high reliability.

Gold plated contacts prevent oxidation and sulfide effect and provide stable contact resistance.

Use of self-extinguishing UL94V-0 certified material in base provides high arc resistance and high insulation resistance.

Gull-wing terminals ensure secure PCB mounting and prevent dislodging during wave soldering.

Terminal spacing conforms to standard .050" (1.27mm) PCB grid.

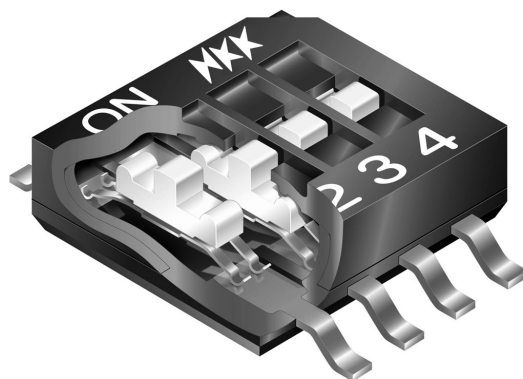

Actual Size



General Specifications

Electrical Capacity (Resistive Load)

Power Level: 25mA @ 24V DC (switching rating)
0.1A @ 50V DC (non-switching rating)

Other Ratings

Contact Resistance: 50 milliohms maximum
Insulation Resistance: 100 megohms minimum @ 100V DC
Dielectric Strength: 300V AC minimum for 1 minute minimum between terminals and between terminals and actuator
Mechanical Life: 2,000 operations minimum
Electrical Life: 2,000 operations minimum
Stroke: .026" (0.65mm)
Operating Force: Less than 4N

Environmental Data

Operating Temp Range: -30°C through +85°C (-22°F through +185°F)

Processing

Soldering: Manual Soldering: 3 seconds max. @ 350°C max.
Reflow Soldering: Infrared reflow recommended, see profile. Depending on the material and the thickness of the PC board, surface temperatures may vary. Do not exceed 250°C. If process exceeds the infrared reflow soldering limits shown in the graph, contact factory for further information.

Cleaning: These devices are not process sealed.
Clean manually with alcohol based solution.

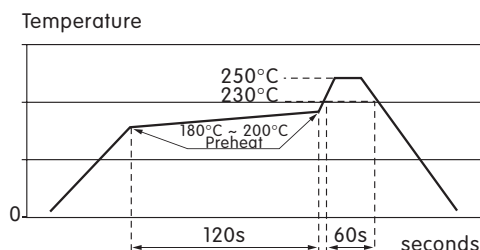

TYPICAL SWITCH ORDERING EXAMPLE

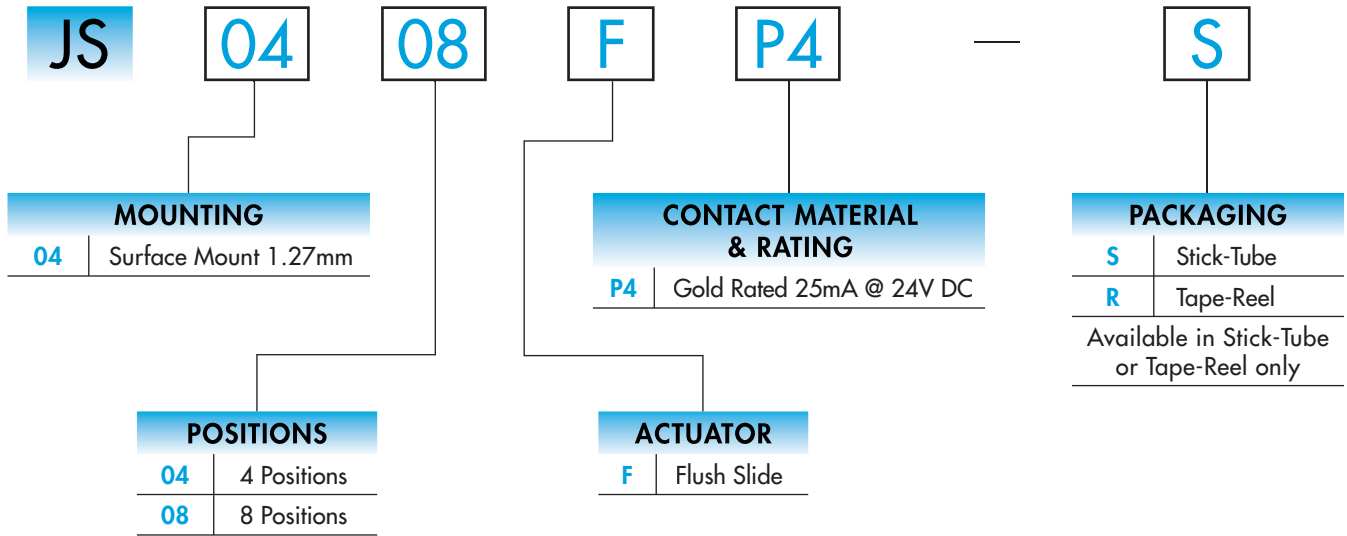

DESCRIPTION FOR TYPICAL ORDERING EXAMPLE

JS0408FP4-S

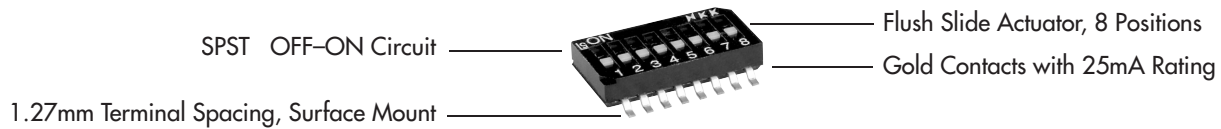

TYPICAL SWITCH DIMENSIONS

Single Pole

4 Positions

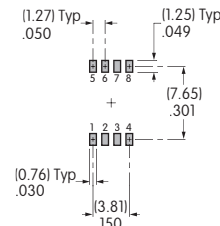
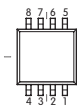
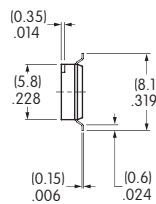
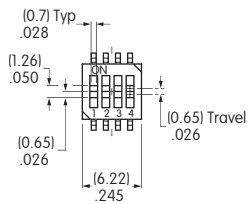
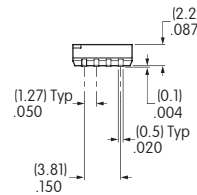
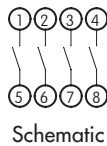

Footprint

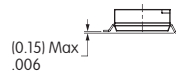

Coplanarity

JS0404FP4

TYPICAL SWITCH DIMENSIONS

8 Positions

Single Pole

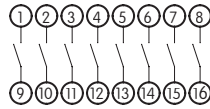

Schematic

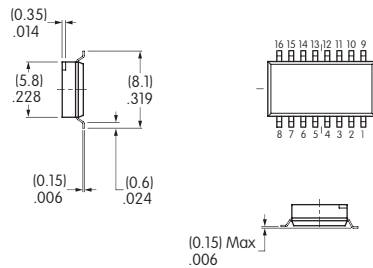
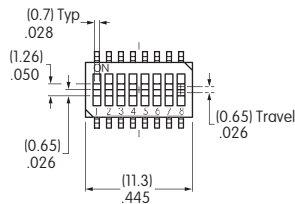
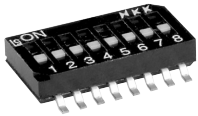

Coplanarity

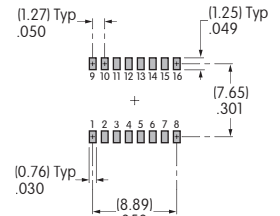

Footprint

JS0408FP4

PACKAGING

S

Stick-Tube Packaging

Switches must be ordered in 80 (JS0404FP4) or 45 (JS0408FP4) piece increments when stick-tube packaging is selected.

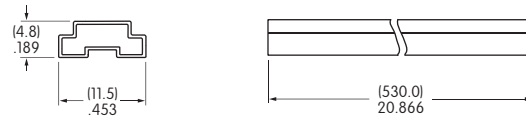

R

Tape-Reel Packaging

Switches must be ordered in 2,000-piece increments when tape-reel packaging is selected.

Each tape-reel contains 2,000 switches.
Minimum Leader Length: 15.75" (400mm)
Minimum Trailer Length: 6.3" (160mm)

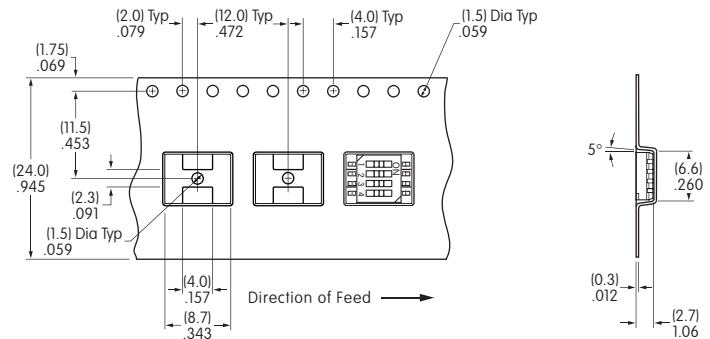

Tape Dimensions for JS0404FP4

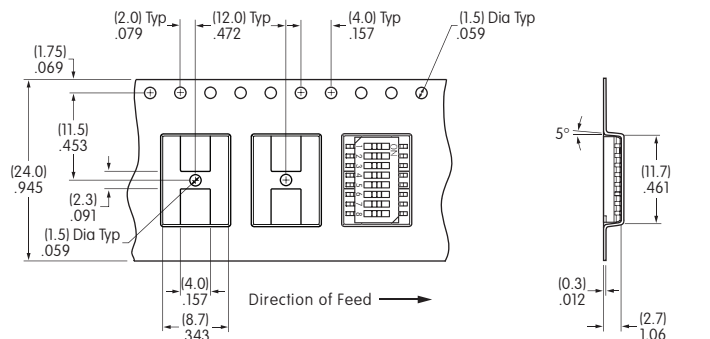
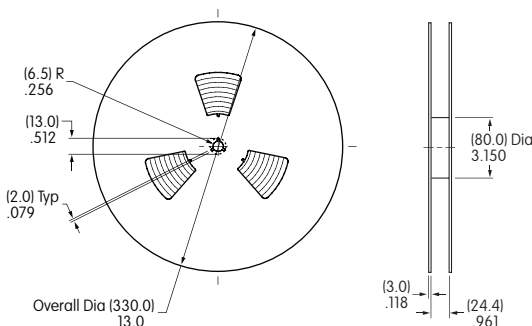

Tape Dimensions for JS0408FP4

Note: Specifications are subject to change without notice. Contact factory for the latest specifications.